



Back Raked RM

market leader in screening



Back Raked RM in production

- ▶ Coarse Bar Screen
- ▶ No bypass required
- ▶ Reduced grid blockages with back raked action
- ▶ Protection for other delicate equipment
- ▶ Ideal for reducing solids loading on existing fine screens

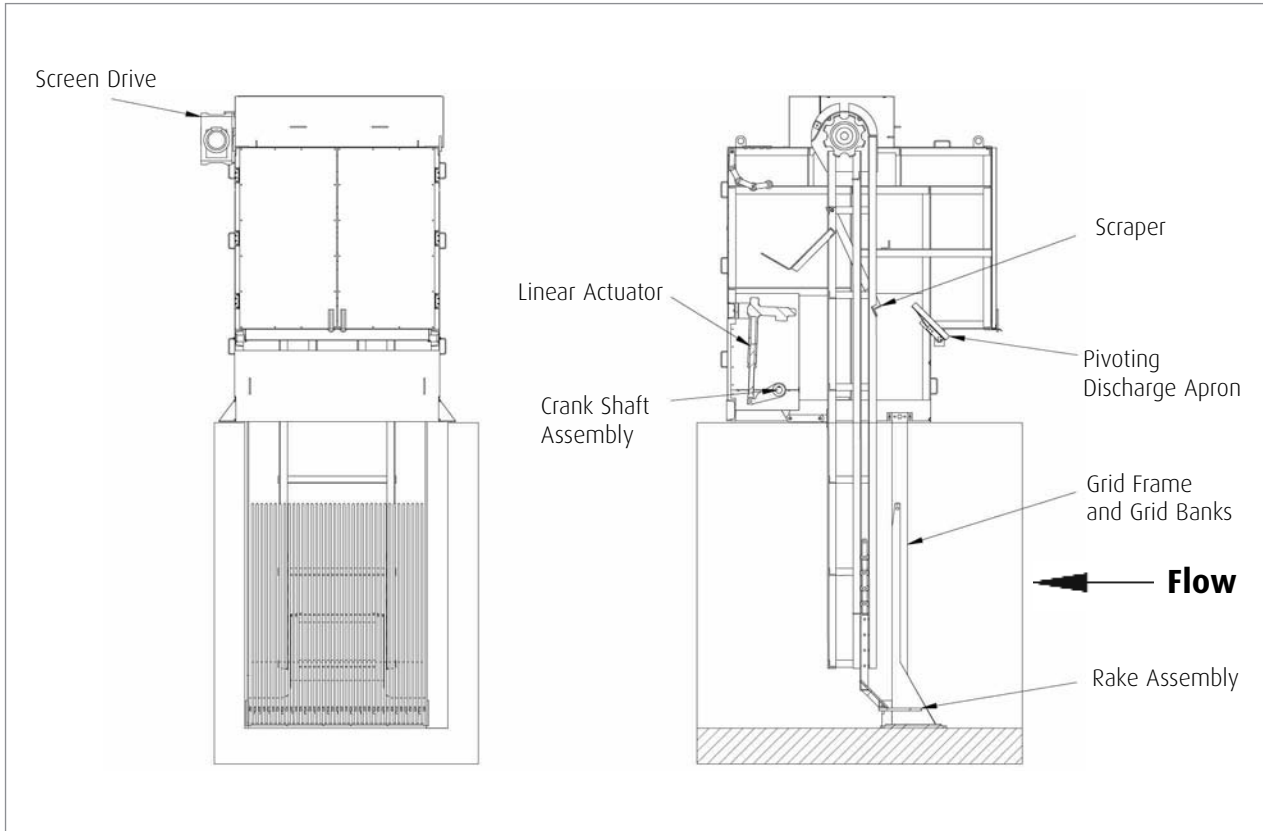

Features and Benefits

- ▶ Various bar sizes and spaces available
- ▶ Grid can be over-topped but still retains large solids
- ▶ Rake is parked out of flow
- ▶ Offers protection to some delicate fine screens
- ▶ Mild steel construction to WIMES specification
- ▶ Screen manufactured to suit existing or new structures
- ▶ No moving parts permanently in the flow
- ▶ No wash water required

Specifications

Min Width	600mm
Max Width	3000mm
Min Channel Depth	750mm
Max Channel Depth	8000mm
Min Flow	25 l/sec
Max Flow	4000 l/sec
Max Depth of Flow	2500mm
Bar Spacing (Min)	20mm
Bar Spacing (Max)	150mm
Bar Width (Min)	10mm
Bar Width (Max)	25mm
Washwater requirements	none