



# Stormguard

market leader in fine storm screening



Stormguard in production at our Huddersfield plant

- ▶ Best performing storm screen at UKWIR test
- ▶ Perforated band screen keeps screenings in foul flow
- ▶ Market lead design, customer influenced
- ▶ Locates directly on to existing weir wall

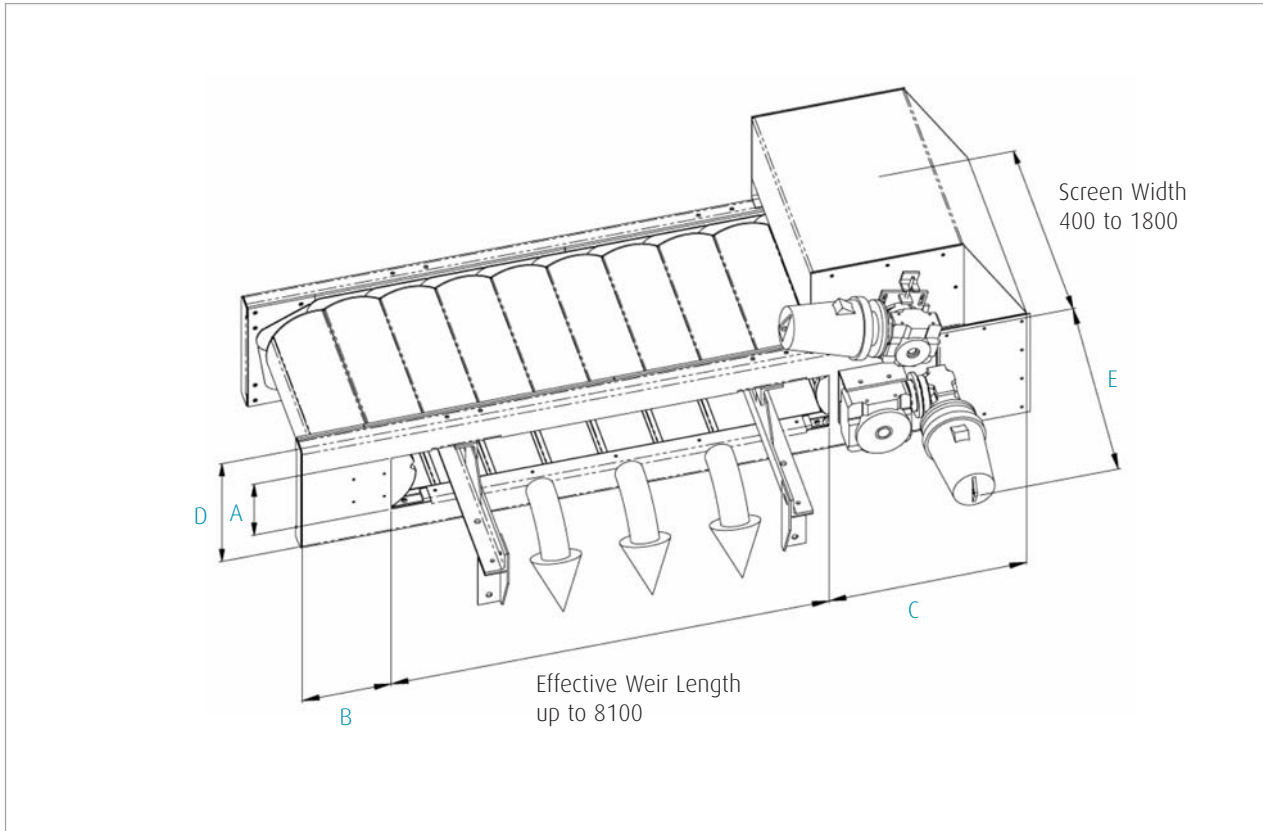

## Features and Benefits

- ▶ Ø6mm perforations
- ▶ Stainless steel construction
- ▶ Single or double sided weirs
- ▶ Screenings retained in the foul flow
- ▶ Modular construction available
- ▶ Capable of up to 5000l/s flows
- ▶ WAPUG chamber design
- ▶ No wash water requirements
- ▶ Mounts on to existing channel and weirs
- ▶ Auto reset if over topped
- ▶ Most efficient screen on the market according to UKWIR
- ▶ Stainless steel as standard with mild steel as an option

Model	200	450	650
Brush Motor	<b>0.75 or 1.5 kW on all models</b>		
Screen Motor	<b>0.75kW</b>	<b>1.5kW</b>	<b>1.5 or 2.2kW</b>
A	<b>250mm</b>	<b>490mm</b>	<b>700mm</b>
B	<b>320mm</b>	<b>450mm</b>	<b>500mm</b>
C	<b>710mm</b>	<b>725mm</b>	<b>725mm</b>
D	<b>480mm</b>	<b>720mm</b>	<b>940mm</b>
E	<b>460mm</b>	<b>460mm</b>	<b>750mm</b>

## Specifications

Min Effective Weir	<b>575mm</b>
Max Effective Weir	<b>8100mm</b>
Min Screen Width	<b>400mm</b>
Max Screen Width	<b>1800mm</b>
Max Flow	<b>up to 5000l/s (per screen)</b>
Min Structural Length	<b>1075mm</b>
Max Structural Length	<b>unlimited (can use more than one screen)</b>