



## Rotapak

market leader in screenings compaction



- ▶ Capacity of 0.5m<sup>3</sup>/hr to 8m<sup>3</sup>/hr dependent on size
- ▶ 3 size options 150, 250, 400
- ▶ Simple well proven design

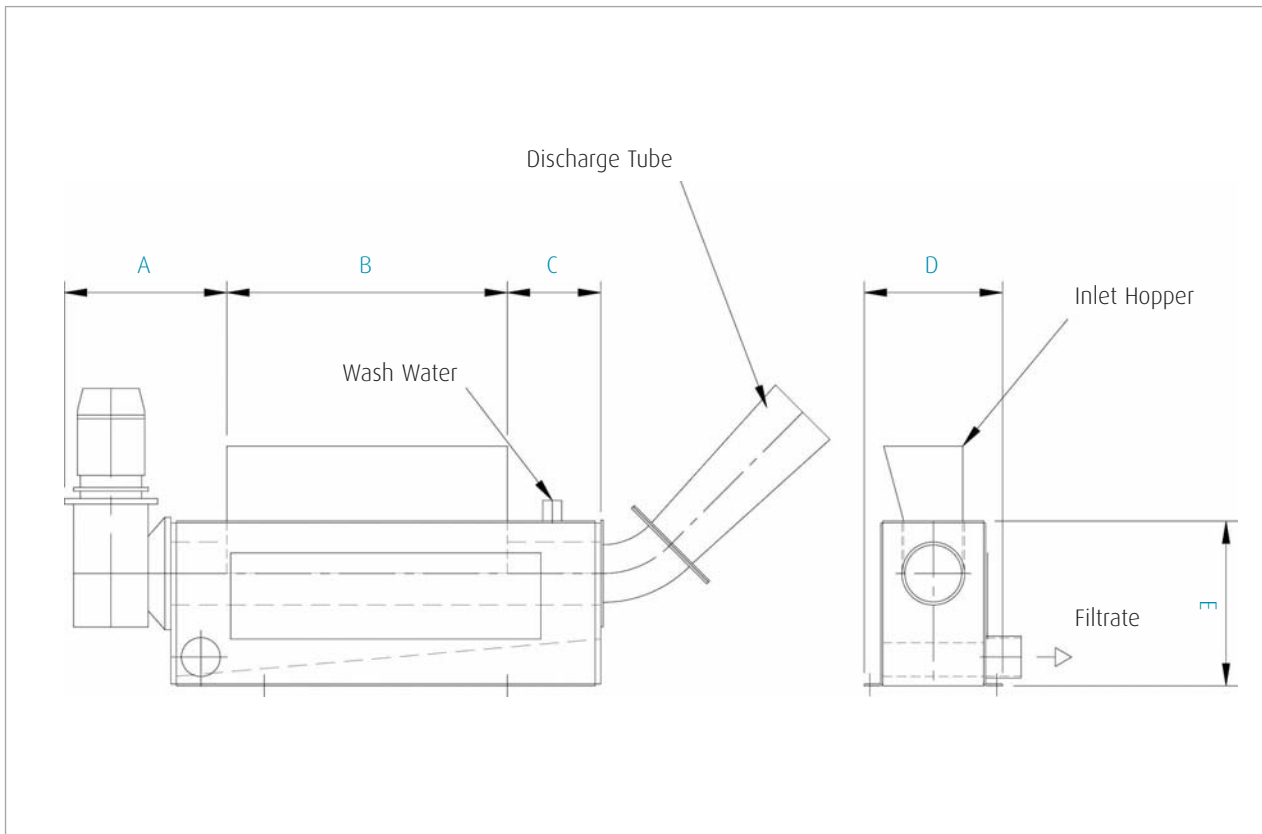

## Features and Benefits

- ▶ Mild steel bodies
- ▶ 3 sizes to suit site demands
- ▶ Can take screenings directly from screen discharge
- ▶ Launder flow acceptance is possible
- ▶ Suitable for sewage or sludge
- ▶ Filtrate returned to main channel, normally under gravity
- ▶ Sparge system optional to give nominal washing action
- ▶ Proven design since 1988
- ▶ Elevated or elongated discharge chute

## Specifications

Model	150	250	400
Capacity	0.5m <sup>3</sup> /hr	2m <sup>3</sup> /hr	3 to 6m <sup>3</sup> /hr
Motor	1.1kW	2.2kW	4 to 7.5kW
A	450mm	650mm	650mm
B	400-2000mm	400-2500mm	600-2500mm
C	250mm	500mm	500mm
D	370mm	520mm	640mm
E	440mm	610mm	750mm
Washwater requirements	2 l/sec		