



The Escalator

market leader in fine channel screening



- ▶ Aperture size 6mm or 3mm for sewage and storm water channel flows
- ▶ Construction in Mild Steel and Stainless Steel (304 or 316)
- ▶ Proven history since 1993, with continual industry lead development
- ▶ Bespoke design to your requirements

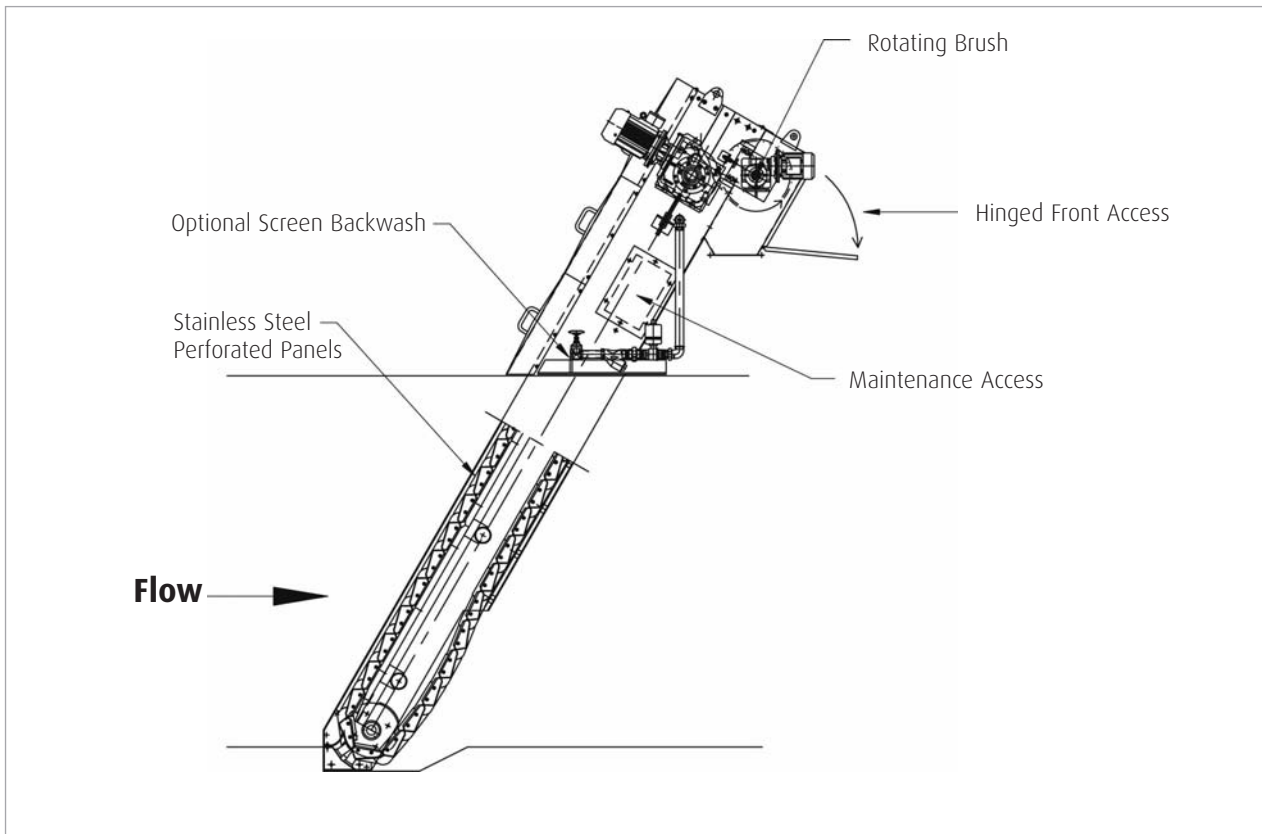

Features and Benefits

- ▶ The Longwood Escalator gives continuous fine screening.
- ▶ Bespoke to your requirements.
- ▶ Standard Ø6mm or optional Ø3mm perforations.
- ▶ Either channel or steel tank mounting.
- ▶ WIMES compliant.
- ▶ Performance testing by UKWIR proved a screenings capture ratio of 73% on all solids
- ▶ Capture ratio of over 95% on all solids greater than 6mm
- ▶ ATEX compliant for Hazardous Areas.
- ▶ Coarse protection is not required.
- ▶ Stainless steel elements carried on specially designed mild steel or stainless steel chains.
- ▶ 60° or 45° screen angle to optimise screenings area.
- ▶ Screen is sized to suit customer requirements.
- ▶ Excellent for retrofitting into existing channels.
- ▶ Self cleaning, patented, deluge system to provide wash-water where site source is unavailable.



450mm diameter Escalator Brushes

Specifications

Min Channel Width	450mm
Max Channel Width	3250mm
Min Channel Depth	500mm
Max Channel Depth	7000mm
Max Flow per screen	4000l/s
Perforations	3mm or 6mm diameter
Screen Angle	45° - 60°
Washwater requirements	2 l/sec @ 4 Bar