



D Screen

market leader in fine screening



D Screen in production at our Huddersfield plant

- ▶ Stand alone perforated screen
- ▶ Proven design with continual development
- ▶ Various perforations available 5, 3, 1.5 and 0.8mm
- ▶ Enclosed unit

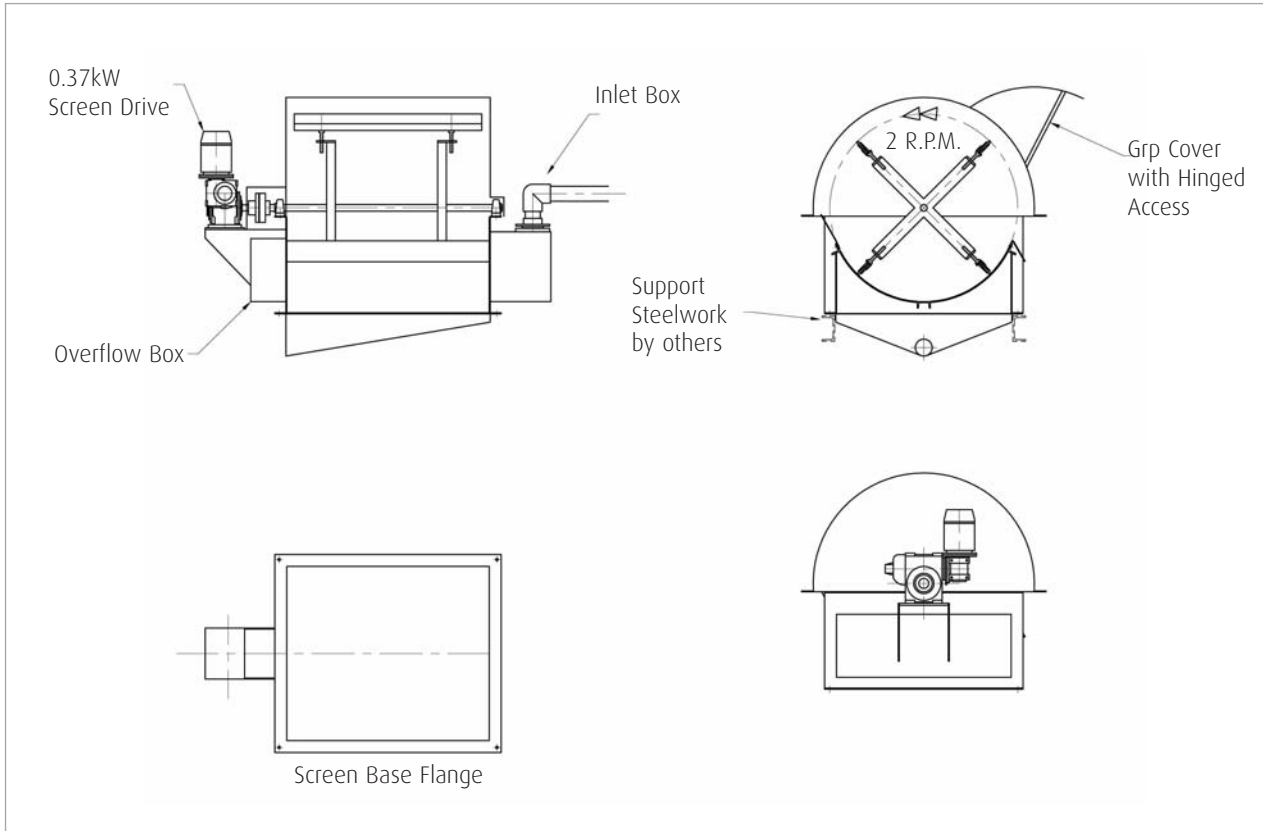

Features and Benefits

- ▶ Mild or stainless steel available
- ▶ Large range of sizes
- ▶ Ideal for industrial and tertiary treatment
- ▶ No need for costly civil excavations
- ▶ Odour control
- ▶ Suitable for pumped and gravity flows
- ▶ Wash water not required
- ▶ Gravity drop flow through the screen



D Screen

Specifications

Length Min	430mm
Length Max	4610mm
Widths	1023mm or 1880mm
Inlet Pipe	250mm or 500mm flanged

Flow capabilities vary depending upon the proportion of solids to liquids. See next page for details.

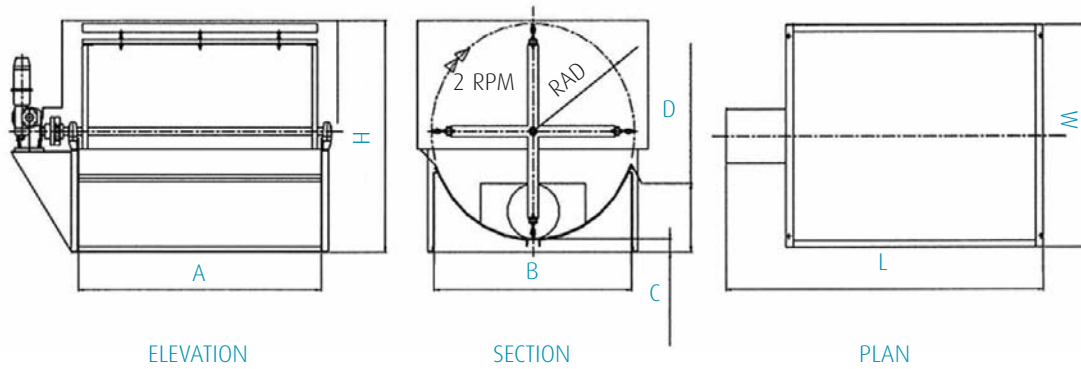

Maximum Inlet Size

- ▶ D4 to D24 including 250mm (10") flanged or socket type
- ▶ D30 to D90 including 500mm (20") flanged or socket type

**Drive
Inlet Adapter
Screen**

- ▶ Preferred opposite inlet
- ▶ Can be designed to suit most types of inlet
- ▶ Perforated stainless steel available with 5,3,1.5 & 0.8mm diameter holes

Brushes

- ▶ Polypropylene

Key

- A Long Outlet
- B Wide Outlet
- C Inlet Invert
- D Screenings Discharge
- H Overall Height Including Cover
- L Overall Length
- W Overall Width

Overall Sizes and Capacities

Type	A	B	C	D	RAD	H	L	W	Nett Weight (kg)	Capacity		kW
										Metric	Imperial	
D90	4610	1880	125	620	970	2150	5660	2000	2540	95 l/sec	1250gpm	1.5
D75	3850	1880	125	620	970	2150	4665	2000	2030	78 l/sec	1030gpm	1.5
D60	3090	1880	125	620	970	2150	4000	2000	1650	62 l/sec	820gpm	0.75
D45	2330	1880	125	620	970	2150	3240	2000	1450	47 l/sec	620gpm	0.75
D30	1570	1880	125	620	970	2150	2480	2000	1220	31 l/sec	410gpm	0.75
D24	2330	1023	75	325	550	1330	2920	1155	550	24.7 l/sec	325gpm	0.37
D20	1950	1023	75	325	550	1330	2540	1155	490	20 l/sec	264gpm	0.37
D16	1570	1023	75	325	550	1330	2160	1155	430	16.4 l/sec	215gpm	0.37
D12	1190	1023	75	325	550	1330	1780	1155	380	12.3 l/sec	160gpm	0.37
D8	810	1023	75	325	550	1330	1400	1155	330	8 l/sec	100gpm	0.37
D4	430	1023	75	325	550	1330	1020	1155	255	3.6 l/sec	50gpm	0.37

These capacities are an approximate guide only and will vary depending on the proportion of solids to liquid in the effluent.

Typical examples

- ▶ Settled sewage prior to percolating filters, capacity x 10
- ▶ Abattoir and tannery effluent (gravity flow), capacity x 0.75
- ▶ Abattoir and tannery effluent (pumping flow), capacity x 0.50

Shipping Spec

L x W x H x Nett Weight ie.without case



Rotapak

market leader in screenings compaction



- ▶ Capacity of 0.5m³/hr to 8m³/hr dependent on size
- ▶ 3 size options 150, 250, 400
- ▶ Simple well proven design

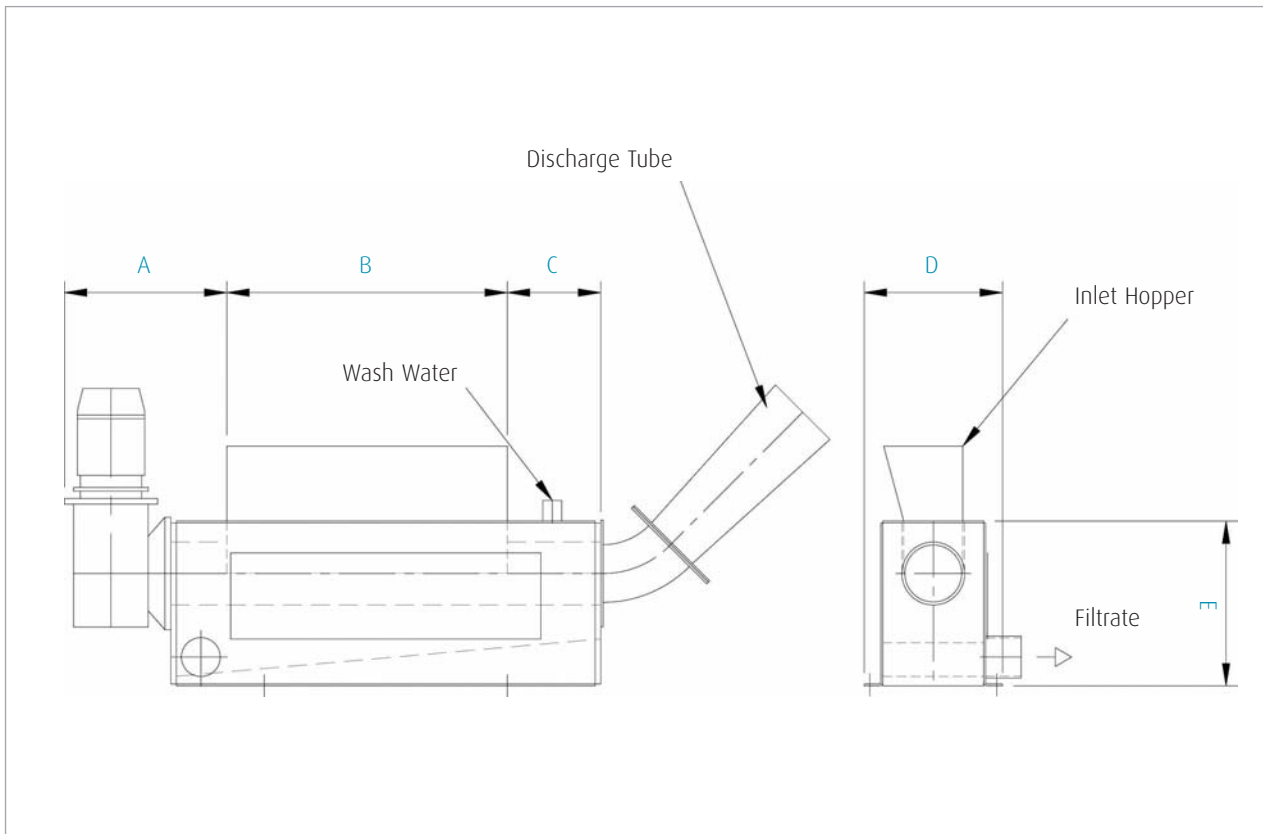

Features and Benefits

- ▶ Mild steel bodies
- ▶ 3 sizes to suit site demands
- ▶ Can take screenings directly from screen discharge
- ▶ Launder flow acceptance is possible
- ▶ Suitable for sewage or sludge
- ▶ Filtrate returned to main channel, normally under gravity
- ▶ Sparge system optional to give nominal washing action
- ▶ Proven design since 1988
- ▶ Elevated or elongated discharge chute

Specifications

Model	150	250	400
Capacity	0.5m ³ /hr	2m ³ /hr	3 to 6m ³ /hr
Motor	1.1kW	2.2kW	4 to 7.5kW
A	450mm	650mm	650mm
B	400-2000mm	400-2500mm	600-2500mm
C	250mm	500mm	500mm
D	370mm	520mm	640mm
E	440mm	610mm	750mm
Washwater requirements	2 l/sec		