



Combi-Wash

market leader in screenings handling



Combi-Wash helical screw

- ▶ Single unit for washing, dewatering and compaction
- ▶ Final product conforms to "the landfill directive"
- ▶ Fed directly by laundered flow
- ▶ Low headroom and small foot print

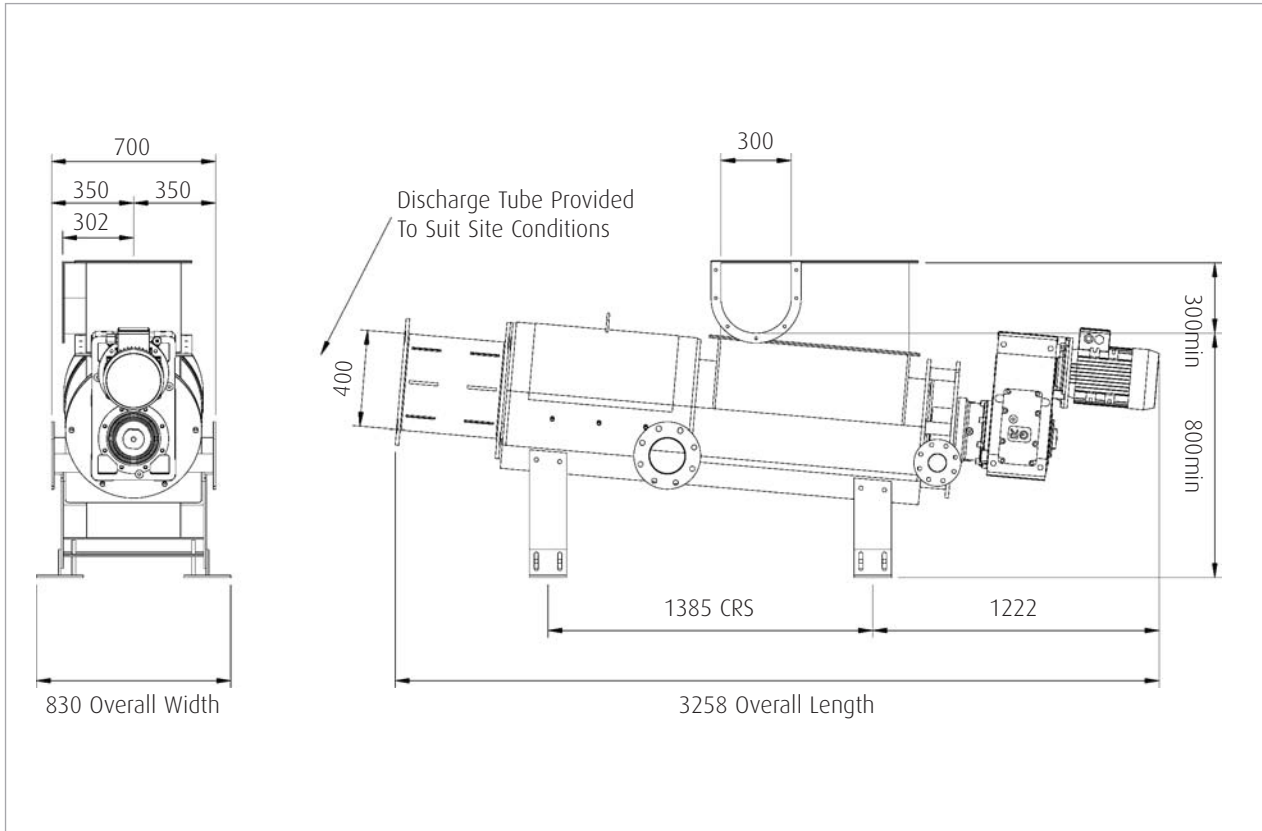

Features and Benefits

- ▶ Single 5.5kW drive
- ▶ 6-15 l/s of launder water capacity
- ▶ Stainless steel as standard, but mild steel option available
- ▶ Simple to retrofit
- ▶ Washes, dewateres and compacts screenings
- ▶ Normal running up to 8m³/hr
- ▶ Storm conditions over 12m³/hr
- ▶ Maceration is not required
- ▶ Unique design for best compaction
- ▶ 25 years of development taken from our Rotapak screw compactor
- ▶ Small foot print
- ▶ Low head room requirement

Specifications

Normal Screenings Capacity
Storm Screenings Capacity
Launder Flow Min
Launder Flow Max
Min Head Requirement
Washwater requirements

up to **8m³/hr**
over **12m³/hr**
6 l/sec
15 l/sec
1100mm
1 l/sec @ 4 Bar